

REVISIONS				
ZONE	REV	DESCRIPTION	DATE	APPROVED
1	PER MARK-UPS		5/30/06	--

ITEM	QTY.	DESCRIPTION	LENGTH	PART NO.
1	AR	3"x3"x¼" 6061-16 ALUM.	-	-
2	AR	1¼" SCH. 40 STR.PIPE 6061-16 ALUM.	-	-
3	AR	1" SCH. 40 STR.PIPE 6061-16 ALUM.	-	-
4	AR	1½" SCH. 40 STR.PIPE 6061-16 ALUM.	-	-
5	.		-	-
20	2	VERTICAL SUPPORT	-	F05-0008-20
21	1	BOTTOM RAIL	-	F05-0008-21
22	2	CONNECTING TUBE	-	F05-0008-22
23	1	UPPER RAIL 'A'	-	F05-0008-23
24	1	GATE RAIL	-	F05-0008-24
25	1	UPPER RAIL 'B'	-	F05-0008-25
26	1	SLIDE PIN	-	F05-0008-26
27	2	MATING PIN	-	F05-0008-27
28	1	GATE STOP	-	F05-0008-28
29	2	HINGE	-	F05-0015
31	1	½"-20 SHOULDER BOLT, (McMaster-Corr)	-	94496A230
32	1	½"-20 NYLOK NUT	-	-
33	1	½" FLAT WASHER	-	-
34	1	BALL KNOB, ø¾" W/ ¼"-20x1" STUD	-	-

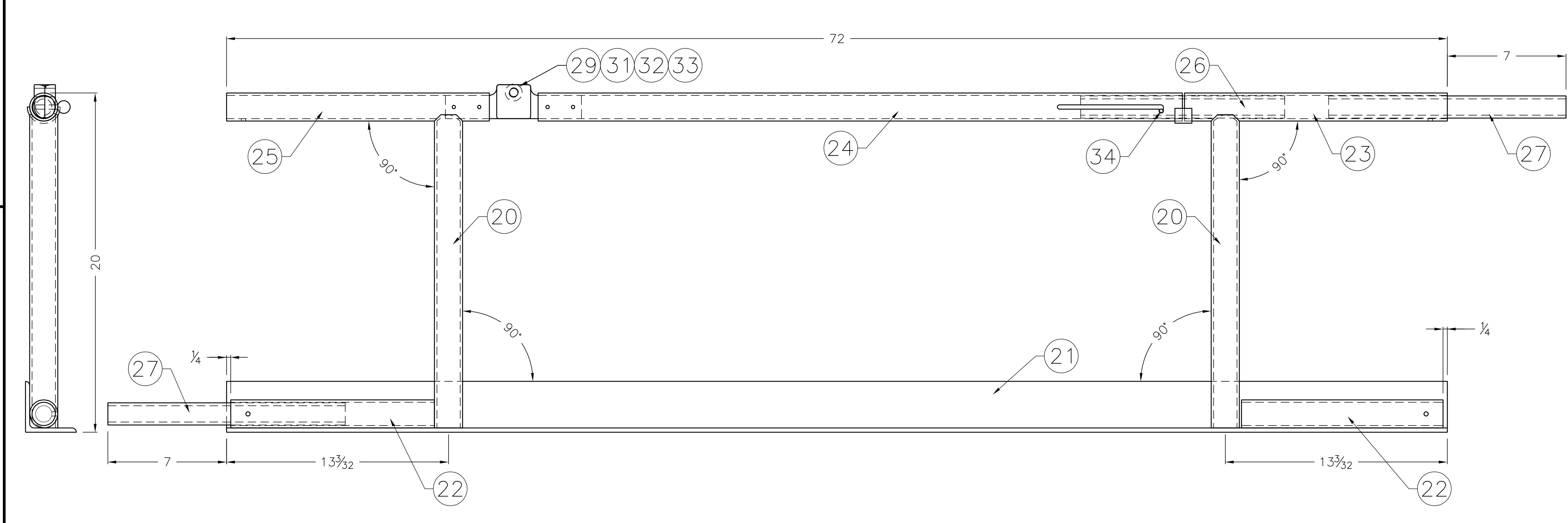

NOTE:  
REMOVE ALL SHARP EDGES.

1 PER MARK-UPS		JR	5/06	TITLE		MATERIAL	
REV.	FROM	BY	DATE	FIELD, RAIL / GATE FABRICATION AND ASSEMBLY		AS NOTED	
UNLESS OTHERWISE SPECIFIED				TOLERANCE			
PERPENDICULAR WITHIN .001"				PARALLEL .001"			
FLAT OR STRAIGHT .001"				CONCENTRIC T.I.R. .001"			
RADI: .001"				SURFACE FINISH			
HOLES: .001"				FSCM			
DRAWN BY		DATE		SCALE		CHECKED	
JRR		12/18/01		1:4		DATE	
SIZE		D		No. F05-0008		SHEET NO. 1	

**FIRST**  
200 Bedford Street, Manchester, N.H. 03101  
(603) 666-3906 • FAX (603) 666-3907